

LPT-11 Link Power Twisted Pair Transceiver Models 50040-02 and 50040R-02

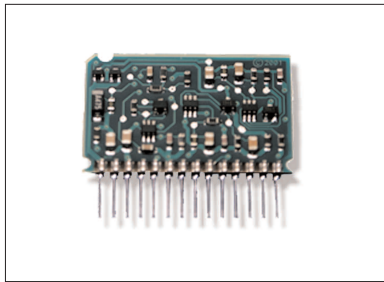

Description

The LPT-11 Link Power Twisted Pair Transceiver provides a simple, cost-effective method of adding a network-powered LONWORKS transceiver to any Neuron® Chip-based control system. The link power system sends power and data on a common twisted wire pair, and allows the user to install LPT-11 transceivers with virtually no topology restrictions. Power is supplied by a customer-furnished nominal 48VDC power supply, flows through the LPI-10 Link Power Interface Module where it is regulated to 42.4VDC, and then passes onto the twisted wire pair. The LPT-11 transceiver eliminates the need to use a local power supply at each node since node power is sent from a central power supply over the same twisted wire pair that handles network communications.

The LPT-11 transceiver consists of a Single In-Line Package (SIP) containing a 78kbps differential Manchester coded communication transceiver, a power supply that extracts power from the twisted pair network, and connections for the Neuron Chip Communications Port (CP) lines and twisted pair network.

The LPT-11 transceiver supports free topology wiring, freeing the system installer from the need to wire in a bus topology. Star, bus, and loop wiring are all supported by this architecture. Free topology wiring reduces the time and expense of system installation by allowing the wiring to be installed in the most expeditious manner. It also simplifies network expansion by alleviating the need for the installer to follow strict rules about stub lengths. Should it be necessary to add more nodes or wire runs in excess of 500 meters, link power segments can be interconnected by a router or a physical layer repeater.

Model 50040R-02 is compliant with the European Directive 2002/95/EC on the restriction of the use of certain hazardous substances (RoHS) in electrical and electronic equipment.

- ▼ Complete LONWORKS® free topology communication transceiver and power supply in a miniature SIP
- ▼ Receives both network data and power on a single twisted wire pair
- ▼ Provides unmatched electrical noise isolation
- ▼ Polarity insensitive network wiring
- ▼ 78 kilobits per second network bit rate for distances up to 500 meters (free topology) and up to 2200 meters (doubly terminated bus topology)
- ▼ Supports free topology star, bus, and loop wiring
- ▼ Compatible with the FTT-10A Free Topology Transceiver, as well as the FT 3120®/FT 3150® Smart Transceivers
- ▼ Supplies 5VDC @ 100mA maximum for node power
- ▼ Meets the requirements of the LONMARK® TP/FT-10 channel type

Typical Wiring Topologies Supported by the LPT-11 Link Power Transceiver

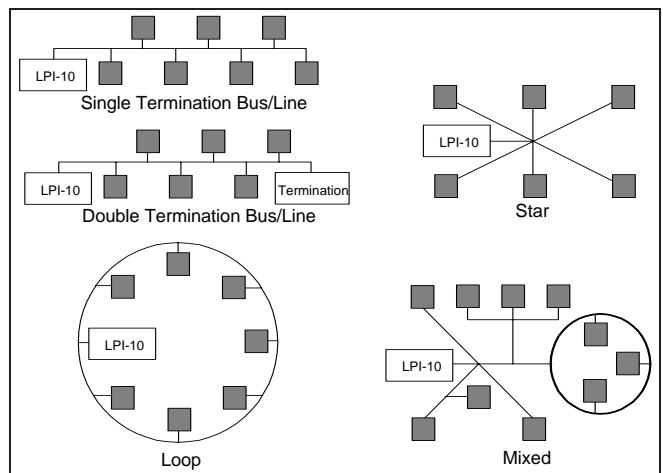

The LPT-11 transceiver includes an integral switching power supply that requires minimal external components to furnish +5VDC at up to 100mA. This current is typically used to power a Neuron Chip and application electronics, sensors, actuators, and displays. The high current capability of the LPT-11 transceiver eliminates the need for local power supplies at each node, resulting in equipment and labor cost savings.

Using the LPT-11 transceiver can save thousands of hours of development time compared with designing a custom transceiver. The transceiver is designed to comply with FCC Part 15, Level B, and CISPR 22 Level B regulations, minimizing time consuming and expensive laboratory transceiver

testing. As a UL, CSA, and TÜV recognized component, the LPT-11 transceiver can be integrated into a product with minimal additional safety testing. The transceiver is small enough to fit into virtually any application, and is economically priced for OEM applications of any volume.

Echelon offers a comprehensive range of development tools, network interfaces, routers, and network services tools to simplify the task of designing products using the LPT-11 transceiver. Technical support for the transceiver is available through Echelon's LonSupport™ Premier technical assistance program.

LPT-11 System Block Diagram

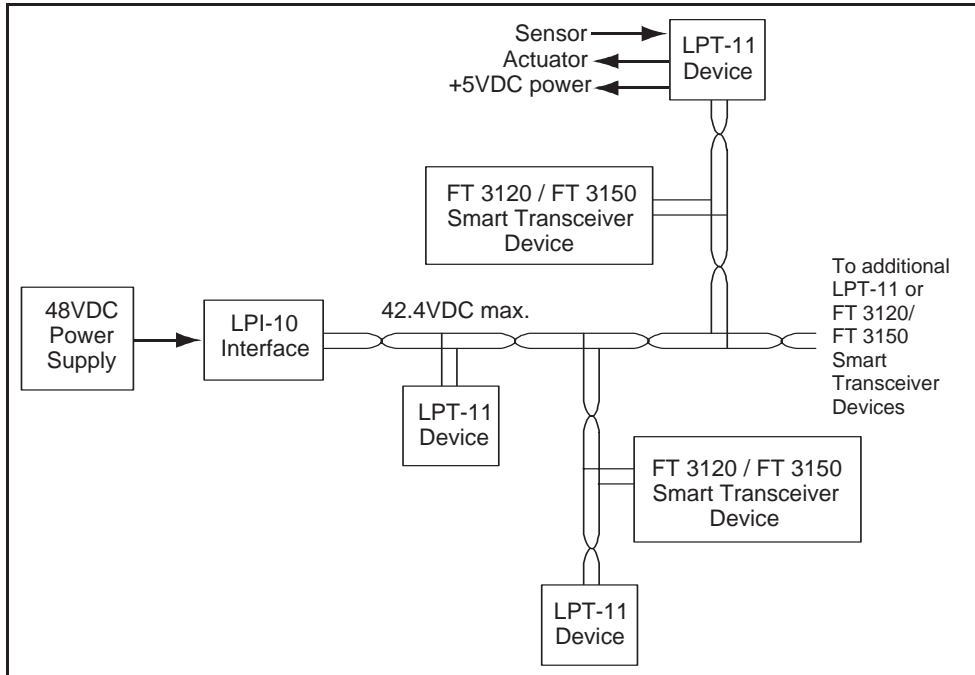

LPT-11 Transceiver Pinout

Name	Pin Number	Function
NET_A	1	Connection to TP network, polarity insensitive
NET_B	2	Connection to TP network, polarity insensitive
V+	3	Power supply input voltage
INDUCTOR	4	Power supply inductor connection
VCC	5	+5VDC power output for device operation
GND	6	Power supply ground
CLK	7	Transceiver clock input from Neuron Chip
NC	8	No Connect (not connected internally)
TXD	9	Neuron Chip CPI
RXD	10	Neuron Chip CP0
NC	11	No Connect (not connected internally)
NC	12	No Connect (not connected internally)
NC	13	No Connect (not connected internally)
NC	14	No Connect (not connected internally)

Mechanical Dimensions

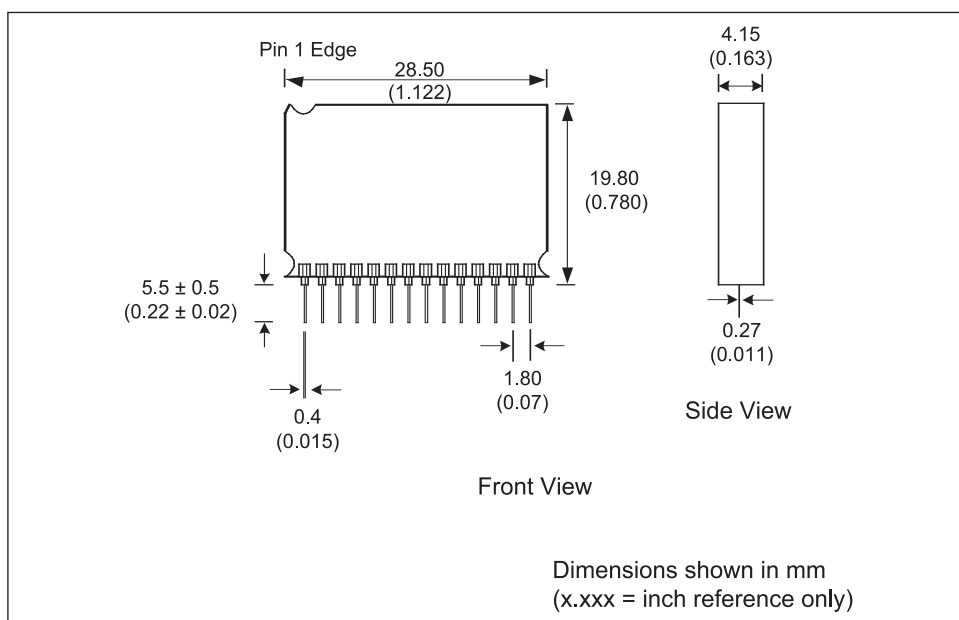

General Specifications

Function	Free topology link power twisted pair transceiver with integral +5VDC power convertor
Data Communications Type	Differential Manchester coding
Network Voltage	42.4VDC supplied by LPI-10 Link Power Interface Module. Nominal 48VDC input to LPI-10 Interface provided by customer's power supply
Application Current Output at Node	100mA @ 5VDC ± 10%
EMI	Designed to comply with FCC Part 15 Level B, EN55022 Level B, and CISPR 22 Level B
ESD	Designed to comply with EN 61000-4-2, Level 4
Radiated Electromagnetic Susceptibility	Designed to comply with EN 61000-4-3, Level 3
Fast Transient/Burst Immunity	Designed to comply with EN 61000-4-4, Level 4 (network cable only)
Surge Immunity	Designed to comply with EN 61000-4-5, Level 3
Conducted RF Immunity	Designed to comply with EN 61000-4-6, Level 3
Listings	Recognized by UL to Standards UL 60950, 2000 and CSA C22.2 No. 60950, 2000 Recognized by TÜV EN 60950
Clock Rates	20, 10, 5, or ² 2.5 MHz input clock. Clock supplied by Neuron Chip and automatically configured by the LPT-11
Transmission Speed	78 kilobits per second
Maximum LPT-11 Devices Per Segment	128 with LPT-11 output of 5VDC @ 25mA 64 with LPT-11 output of 5VDC @ 50mA 32 with LPT-11 output of 5VDC @ 100mA
Network Cabling	¹ See User's Guide for compatible cables
Network Length in Free Topology	² 1000m (3,280 feet) maximum total wire with one repeater ³ 500m (1,640 feet) maximum total wire with no repeaters ³ 500m (1,640 feet) maximum node-to-node distance
Network Length in Doubly Terminated Bus Topology	² 4400m (14,430 feet) with one repeater ² 2200m (7,210 feet) with no repeaters
Network Bus Polarity	Polarity insensitive
Power-down Network Protection	High impedance when unpowered
Connector	Thru-hole pins (1.8mm spacing)
Network Terminator	Termination in LPI-10 Link Power Interface Module
Operating Temperature	-40 to +85°C
Non-operating Temperature	-40 to +85°C

Operating Humidity (non-condensing)	25-90% RH @ 70°C
Non-operating Humidity (non-condensing)	95% RH @ +70°C
Packaging	Single In-line Package

Ordering Information

Product	Echelon Model Number
LPT-11 Link Powered Twisted Pair Transceiver	50040-02, 50040R-02
<i>LONWORKS LPT-11 Link Power Transceiver User's Guide</i> (order separately — not shipped with product)	078-0198-01
<i>LONWORKS LPI-10 Link Power Interface Module User's Guide</i> (order separately — not shipped with product)	078-0104-01

Notes:

1. For compliance to the LONMARK TP/FT-10 Channel, cable must comply with ANSI/TIA/EIA-568-A-1995 Category 5 requirements for 24 AWG unshielded twisted-pair cable.
2. Network length varies depending on wire type. Level-4 wire used in examples. See *LONWORKS LPT-11 Link Power Transceiver User's Guide*, or *Junction Box and Wiring Guidelines for Twisted Pair LONWORKS Networks, 005-0023-01 Rev. K or later*, for detailed specifications.
3. Operation at 2.5MHz does not comply with LONMARK guidelines for the TP/FT-10 channel. 1.25MHz operation is not supported.

Copyright © 2003-2006, Echelon Corporation. Echelon, LON, LONWORKS, LONMARK, LonBuilder, NodeBuilder, LonManager, LonTalk, LonUsers, LonPoint, Digital Home, Neuron, 3120, 3150, LNS, iLON, LonWorld, ShortStack, Panoramix, LonMaker, the Echelon logo, and the LonUsers logo are trademarks of Echelon Corporation registered in the United States and other countries. LonLink, LonResponse, LonSupport, LONews, Open Systems Alliance, OpenLDV, Powered by Echelon, LNS Powered by Echelon, Panoramix Powered by Echelon, LONWORKS Powered by Echelon, Networked Energy Services Powered by Echelon, NES Powered by Echelon, Digital Home Powered by Echelon, Pyxos, and Thinking Inside the Box are trademarks of Echelon Corporation. Other trademarks belong to their respective holders.

Disclaimer

Neuron Chips, Free Topology Twisted Pair Transceiver Modules, and other OEM Products were not designed for use in equipment or systems which involve danger to human health or safety or a risk of property damage and Echelon assumes no responsibility or liability for use of the Neuron Chips or Free Topology Twisted Pair Transceiver Modules in such applications. ECHELON MAKES AND YOU RECEIVE NO WARRANTIES OR CONDITIONS, EXPRESS, IMPLIED, STATUTORY OR IN ANY COMMUNICATION WITH YOU, AND ECHELON SPECIFICALLY DISCLAIMS ANY IMPLIED WARRANTY OF MERCHANTABILITY OR FITNESS FOR A PARTICULAR PURPOSE.

003-0356-01B