

## DIO-10 Digital Input Output Interface Module Model 41500



### LonPoint™ Modules

The LonPoint Modules are products designed to integrate new and legacy sensors and actuators, as well as LONMARK® devices, into cost-effective, interoperable, control systems for building and industrial applications. In contrast to traditional control networks, which use closed islands of control linked with proprietary gateways, the LonPoint Modules offer an open distributed system architecture in which every device performs some control processing and can be accessed from any location in the network. Distributing the processing throughout the network and providing open access to every device lowers the overall installation and life cycle costs, increases reliability by minimizing single points of failure, and provides the flexibility to adapt the system to a wide variety of applications.

The system consists of the LonPoint Interface, Scheduler, Data Logger, Router Modules, LonPoint Application Programs, LNS™ based LonMaker™ Integration Tool, LonPoint Plug-In, and LNS DDE Server.

### DIO-10 Module

The DIO-10 Module is a LONMARK device that provides two digital input and two relay outputs. The digital inputs can monitor dry contacts or 31VDC voltage inputs. The two relay contacts are rated at 2A continuous and 6A surge at 30VAC or 42VDC. Separate Status LEDs are provided for each input and output. Separate Hand/Off/Auto switches are provided for each relay output. The module operates from 16 to 30 VAC or VDC, allowing it to be powered from the same sources as the sensors.

Resident within the module is a powerful, configurable application program. The program includes a variety of software function blocks (LONMARK objects) that define how the module will function. Digital Input/Counter functional blocks provide configurable debouncing, inversion, override, and heartbeat control in addition to time, count, and frequency-based processing control of the digital inputs. Digital Output

- ▼ Seamlessly integrates legacy digital sensors and actuators into interoperable LONWORKS® networks
- ▼ Two digital inputs support dry contact, 5V, 12V, 24V, 31V
- ▼ Two relay outputs rated at 2A continuous and 6A surge at 30VAC or 42VDC
- ▼ Status LEDs for each input and output
- ▼ Programmable input threshold levels on both digital inputs
- ▼ Hand/Off/Auto switches on the front panel for manual control of the two relay outputs
- ▼ Hardware support for high-speed (up to 20KHz) frequency measurement on both digital inputs
- ▼ LNS Plug-In
- ▼ U.L. Listed, cU.L. Listed, CE Mark, LONMARK

functional blocks provide configurable debouncing, inversion, time-based processing, override, and heartbeat control of the digital outputs. Digital Encoder functional blocks encode up to four digital values to produce configurable digital and mode outputs. Analog function blocks perform configurable logic, math, or enthalpy calculations on two analog inputs to generate analog and digital outputs. Type Translator functional blocks convert any input network variable type to any output network variable type using a configurable translation table.

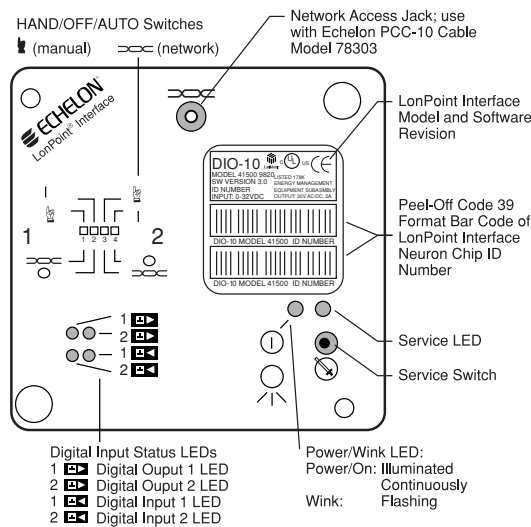

LonPoint DIO-10 Digital Input/Output Module—Front Panel

Using the LonMaker tool, the user links together the function blocks of the DIO-10, other LonPoint modules, and other LONMARK and LONWORKS® devices, to create an open, distributed control system. Network design and configuration is

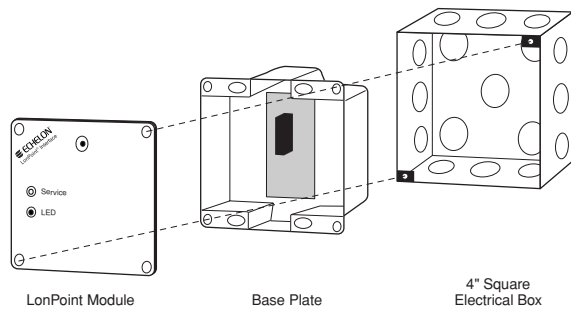

*LonPoint Interface Module 4" Square by 2" Deep  
Electrical Box Mounting Configuration*

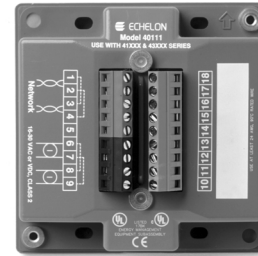

*Type 1 Base Plate Front View*

simplified by the Visio® interface of the LonMaker tool, which can both import and export AutoCAD® files and generate as-built documentation. The user configures the DIO-10 Module using the simple and intuitive interface provided by the LonPoint Plug-In.

Moves, adds, and changes can be easily accommodated by downloading configuration changes into the LonPoint module's flash memory—either locally or via remote LONWORKS or Internet network connection.

A unique, two-piece design allows pre-wiring and cable testing by an electrician prior to installation of the electronics; technician time can be reserved for tasks such as device configuration. Power and network wiring are looped through the base plate, providing the ability to replace modules by hot-plugging without disrupting network operation.

Polarity-insensitive power and network connections minimize the chance of miswiring, and the free topology design allows wiring to be run via the most convenient route. A front panel jack allows a person access to the twisted pair network without any disassembly, saving time when the network must be accessed for remote node configuration and maintenance.

A front panel bar code with the model, revision, and two removable Neuron® ID stickers is provided. When placed on the building or system design plans, these stickers can save installation time, especially for inaccessible devices.

## Mounting

The DIO-10 Module can be mounted to a Type 1 Base Plate, (which is in turn mounted to either a 4" square by 2" deep electrical box) or a Type 1D DIN Base Plate (for wall or 35mm DIN-rail mounting)

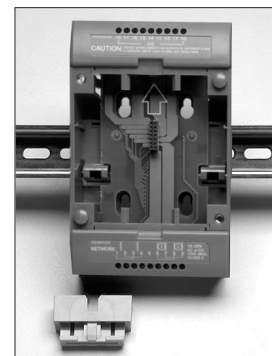

*Type 1D Base Plate Front View*

## Specifications

Function	Description
Processor/memory	Neuron 3150® Chip, 10MHz, 56K flash memory
Service function	Recessed service switch, service LED, power/wink LED. Dual tear-off bar-code Neuron ID self-adhesive tag
I/O	2 digital inputs, 5, 12, 24, 31V or dry contact. Up to 20kHz frequency measurement. Two relay outputs (each has one Form A and one Form B contact with a common wiper) rated at 2A continuous, 6A surge at 30 VAC or 24 VDC. Separate status LEDs for each input
I/O isolation	100V, transformer isolation. Inputs are isolated from the input power and the network but not from each other
Transceiver type	FTT-10A with blocking capacitors for compatibility with link power channel
Input power	16-30VAC or VDC @ 4.75VA, internally isolated power supply
Mounting	Type 1 or Type 1D Base Plate
Temperature	-40 to +85°C, operating and non-operating
Humidity	10 to 95% RH @50°C
Safety agency	U.L.916
EMC	FCC A, CE Mark
Functional Blocks	Digital Input/Counter function block (2), Digital Output function block (2), analog function block (2) Digital Encoder function block (2), Type Translator function block (4) and node Object (1)
Software configuration	LONMARK configuration properties configured by an LNS plug-in. The LNS plug-in is compatible with LNS tools supporting the LNS plug-in standard, including the LonMaker Integration Tool
LONMARK status	Certified to meet LONMARK Interoperability Guidelines.
Dimensions	3.9" x 3.9" x 1" (10cm x 10cm x 2.5cm)

Copyright © 1999-2002, Echelon Corporation. Echelon, LON, LonWorks, LonMARK, LonBuilder, Nodebuilder, LonManager, Digital Home, LonTalk, Neuron, 3120, 3150, the LonMark logo, and the Echelon logo are trademarks of Echelon Corporation registered in the United States and other countries. LNS, the LNS Powered Logo, LonPoint, SMX, LonResponse, LONews, LonSupport, LonMaker, iLON, Bringing the Internet to Life, Open Systems Alliance, and the Open Systems Alliance logo are trademarks of Echelon Corporation. Windows and Windows NT are U.S. registered trademarks of Microsoft Corporation. Other trademarks belong to their respective corporations.

### Disclaimer

Neuron Chips, Free Topology Twisted Pair Transceiver Modules, and other OEM Products were not designed for use in equipment or systems which involve danger to human health or safety or a risk of property damage and Echelon assumes no responsibility or liability for use of the Neuron Chips or Free Topology Twisted Pair Transceiver Modules in such applications. ECHELON MAKES AND YOU RECEIVE NO WARRANTIES OR CONDITIONS, EXPRESS, IMPLIED, STATUTORY OR IN ANY COMMUNICATION WITH YOU, AND ECHELON SPECIFICALLY DISCLAIMS ANY IMPLIED WARRANTY OF MERCHANTABILITY OR FITNESS FOR A PARTICULAR PURPOSE.

003-0304-01D