

DO-10 Digital Output Interface Module Model 41200

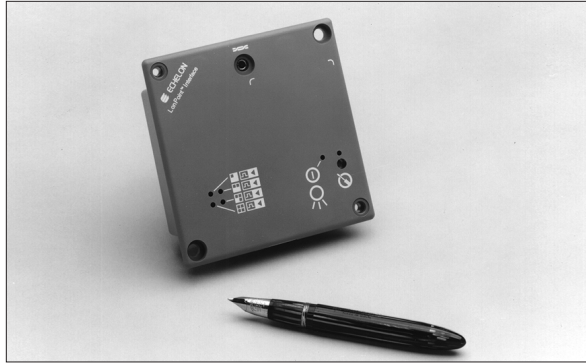

LonPoint™ Modules

The LonPoint Modules are products designed to integrate new and legacy sensors and actuators, as well as LONMARK® devices, into cost-effective, interoperable, control systems for building and industrial applications. In contrast to traditional control networks, which use closed islands of control linked with proprietary gateways, the LonPoint Modules offer an open distributed system architecture in which every device performs some control processing and can be accessed from any location in the network. Distributing the processing throughout the network and providing open access to every device lowers the overall installation and life cycle costs, increases reliability by minimizing single points of failure, and provides the flexibility to adapt the system to a wide variety of applications.

The system consists of the LonPoint Interface, Scheduler, Data Logger, Router Modules, LonPoint Application Programs, LNS™ based LonMaker™ Integration Tool, LonPoint Plug-In and LNS DDE Server.

DO-10 Module

The DO-10 Module is a LONMARK a device that provides 4 digital outputs, 0-12V, 100mA source/sink maximum on any one output, 110mA source/400mA sink on all outputs combined. Separate hand/off/auto front panel DIP switches, and status LEDs, are provided for each output. The module operates from 16 to 30VAC or VDC, allowing it to be powered from the same sources as the actuators.

Resident within the module is a powerful, configurable application program. The program includes a variety of software functional blocks (LONMARK objects) that define how the module will function. Digital Output functional blocks provide configurable debouncing, inversion, time-based processing, preset, override, and heartbeat control of the digital outputs. Digital Encoder functional blocks encode up to four digital values to produce configurable digital and mode outputs. Analog Function Blocks perform configurable logic, math, or

- ▼ Seamlessly integrates digital actuators into interoperable LONWORKS® networks
- ▼ 4 digital outputs: 0-12VDC
- ▼ Separate hand/off/auto switch and status LED for each output
- ▼ Flash memory: download via network
- ▼ Network access from front panel jack
- ▼ Two-piece design cuts installation time, cost
- ▼ LNS Plug-In
- ▼ U.L. Listed, cU.L. Listed, CE Mark, FCC, LONMARK

enthalpy calculations on two analog inputs to generate analog and digital outputs. Type Translator functional blocks convert any input network variable type to any output network variable type using a configurable translation table. Using the LonMaker tool, the user links together the functional blocks of the DO-10 Module, other LonPoint modules, and other LONMARK and LONWORKS devices, to create an open distributed control system. Network design and configuration is simplified by the Visio® interface of the LonMaker tool, which can both import and export AutoCAD® files and generate as-built documentation. The user configures the DO-10 Module using the simple and intuitive interface provided by the LonPoint Plug-In.

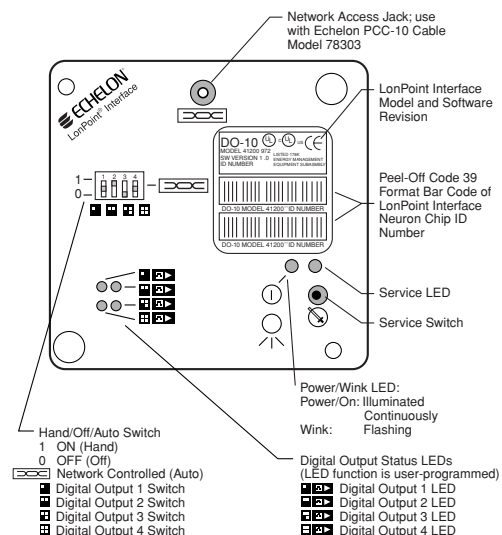

Moves, adds, and changes can be easily accommodated by downloading configuration changes into the LonPoint module's flash memory—either locally or via remote LONWORKS or Internet network connection.

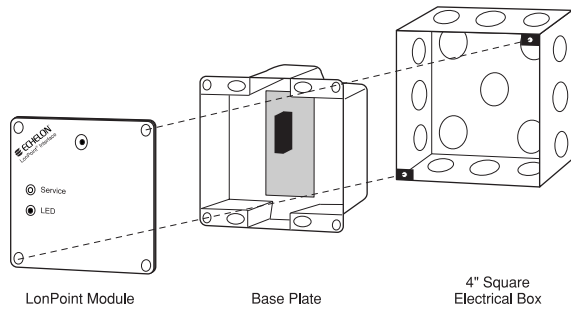

LonPoint Interface Module 4" Square by 2" Deep Electrical Box Mounting Configuration

A unique, two-piece design allows pre-wiring and cable testing by an electrician prior to installation of the electronics; technician time can be reserved for tasks such as device configuration. Power and network wiring are looped through the base plate, providing the ability to replace modules by hot-plugging without disrupting network operation.

Polarity-insensitive power and network connections minimize the chance of miswiring, and the free topology design allows wiring to be run via the most convenient route. A front panel jack accesses the twisted pair network without any disassembly, saving time when the network must be accessed for configuration or maintenance.

A front panel bar code with the model, revision, and two removable Neuron® ID stickers is provided. When placed on the building or system design plans, these stickers can save installation time, especially for inaccessible devices.



Type 1 Base Plate — Front View

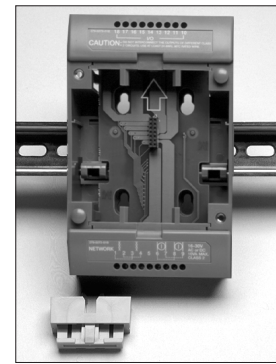

Type 1D DIN Base Plate

Mounting

The DO-10 may be used with either a Type 1 Base Plate (for use with 4" square electrical boxes) or a Type 1D DIN Base Plate (for panel, wall, or 35mm DIN-rail mounting).

Specifications

Function	Description
Processor/memory	Neuron 3150® Chip, 10MHz, 56K flash memory
Service function	Recessed service switch, service (wink) LED. Dual tear-off bar-code Neuron ID self-adhesive tag
I/O	4 digital outputs, 0-12V, 100mA source/sink maximum on any one output, 110mA source/400mA sink on all outputs combined; separate status LEDs for each output; separate hand/off/auto front panel DIP switches for each output
I/O isolation	100V, transformer isolation. Outputs are isolated from the input power and the network but not from each other
I/O connector	9 screw terminal, non-removable, wire clamp style, supports 12-24AWG (2 to 0.5mm) wire
Transceiver type	FTT-10A with blocking capacitors for compatibility with link power channel
Input power	16-30VAC or DC @ 3.2 to 6.5VA (25mA per output) depending on load, internally isolated power supply
Mounting	Type 1 Base Plate or Type 1D DIN Base Plate
Temperature	-40 to +85°C, operating and non-operating
Humidity	10 to 95% RH @ 50°C
EMI	FCC A, CE Mark
Safety agency	U.L. 916
Functional blocks	Node object (1), digital output open-loop actuator objects (4), digital encoder controller objects (2), analog function block controller objects (2), type translators (6)
Software configuration	LONMARK configuration properties configured by an LNS plug-in. The LNS plug-in is compatible with LNS tools supporting the LNS plug-in standard, including the LonMaker Integration Tool
LONMARK status	Certified to meet LONMARK Interoperability Guidelines
Dimensions	3.9" x 3.9" x 1" (10cm x 10cm x 2.5cm)

Copyright © 1999-2002, Echelon Corporation. Echelon, LON, LonWORKS, LONMARK, LonBuilder, Nodebuilder, LonManager, Digital Home, LonTalk, Neuron, 3120, 3150, the LonMark logo, and the Echelon logo are trademarks of Echelon Corporation registered in the United States and other countries. LNS, the LNS Powered Logo, LonPoint, SMX, LonResponse, LONews, LonSupport, LonMaker, iLON, Bringing the Internet to Life, Open Systems Alliance, and the Open Systems Alliance logo are trademarks of Echelon Corporation. Windows and Windows NT are U.S. registered trademarks of Microsoft Corporation. Other trademarks belong to their respective corporations.

Disclaimer

Neuron Chips, Free Topology Twisted Pair Transceiver Modules, and other OEM Products were not designed for use in equipment or systems which involve danger to human health or safety or a risk of property damage and Echelon assumes no responsibility or liability for use of the Neuron Chips or Free Topology Twisted Pair Transceiver Modules in such applications. ECHELON MAKES AND YOU RECEIVE NO WARRANTIES OR CONDITIONS, EXPRESS, IMPLIED, STATUTORY OR IN ANY COMMUNICATION WITH YOU, AND ECHELON SPECIFICALLY DISCLAIMS ANY IMPLIED WARRANTY OF MERCHANTABILITY OR FITNESS FOR A PARTICULAR PURPOSE.

003-0135-01D